

## All Metal Lock Nut

**Thread Type:** Metric - Coarse

**Thread Direction:** Right Hand

**Material:** Stainless Steel

**Class Grade:** A4-70 G316

**Corrosion Protection Level:** Ultimate

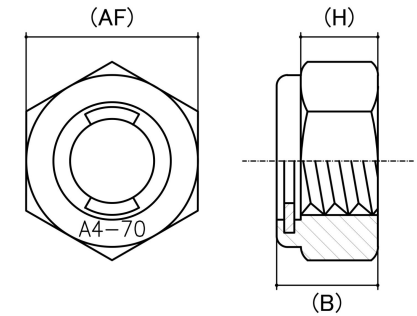

*CAD drawings shown for graphic representation only.\**

Size	Thread Pitch (mm)	Thread Type	Overall Nut Height (B) (mm)	Hex Height (H) (mm)	Across Flats (AF) (mm)		Spanner Size (AF) (mm)	sku (qfind)
			Nom	Nom	Min	Max		
M4	0.70	Coarse	4.00	3.10	6.78	7.00	7	41AMLS4M
M5	0.80	Coarse	5.10	3.80	7.78	8.00	8	41AMLS5M
M6	1.00	Coarse	5.40	4.80	9.78	10.00	10	41AMLS6M
M8	1.25	Coarse	6.90	5.60	12.73	13.00	13	41AMLS8M
M10	1.50	Coarse	8.50	6.80	16.73	17.00	17	41AMLS10M
M12	1.75	Coarse	10.30	8.70	18.67	19.00	19	41AMLSM12M
M16	2.00	Coarse	14.60	12.30	23.67	24.00	24	41AMLS16M
M20	2.50	Coarse	17.30	15.00	29.16	30.00	30	41AMLS20M

**Disclaimer:**

Dimensional data and technical information was obtained from publically available sources and not acquired through standard agencies. It has been completed and compiled for reference purposes only; where discrepancies are found they are subject to change without notice. Bolt & Nut Australia makes no warranties or representations regarding the accuracy and validity of the compiled information and data. Contact the relevant standard authorities for accurate and detailed information.

\* CAD drawings may not reflect diameter, thread length or overall length.

© Bolt & Nut Australia Pty Ltd. All rights reserved.

Version: 18 Mar 2024